

# TYPE DBT - 100

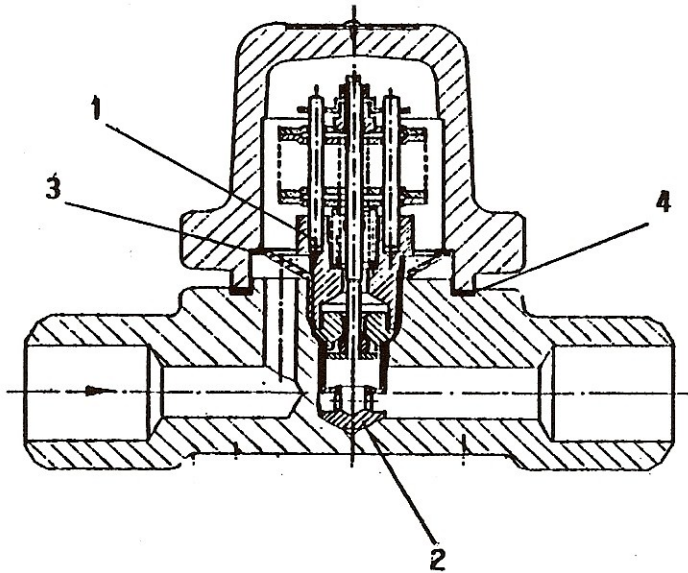

Spare Parts	
Item No.	Description
1	Bimetallic Regulator
2	Lining Insert
3	Strainer
4	Cover Gasket graphite/CrNi
5	Socket Head Cap Screw M12x35

Weight: 3.5 kgs (for NPT/SW)

### Maintenance Information:

Torque for tightening of body parts  
at room temperature:

- Part #1 Bimetallic Regulator = 100Nm
- Part #6 Socket Head cap screw = 60 Nm

### When ordering please state:

Application, operating pressure,  
back pressure, hot condensate capacity,  
connection & size

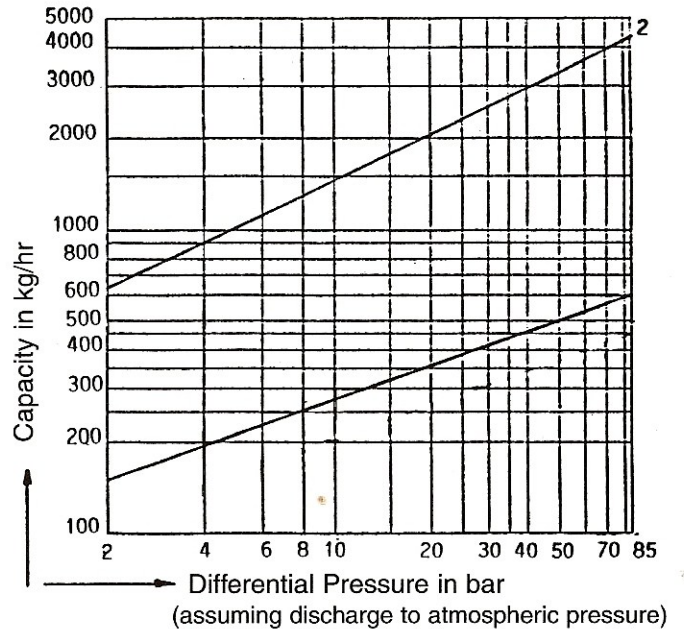

### Capacity Chart:

Curve #1 - Factory setting for hot condensate  
capacity ca.  $t = 25K$

Curve #2 - Cold condensate capacity



### DOMNIK CANADA INC.

561 Edward Avenue, Unit 5, Richmond Hill, Ontario, Canada  
L4C 9W6 Tel: (905) 508-9653 Fax: (905) 508-0138  
Email: domnik@domnikcanada.com  
www.domnikcanada.com